

BGV120

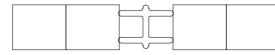

BGV1200

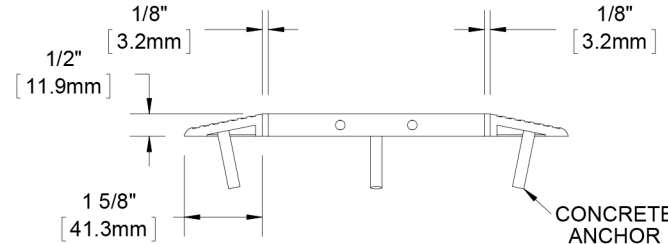
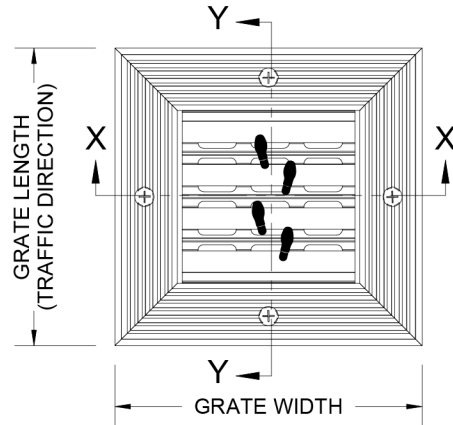

SECTION X-X

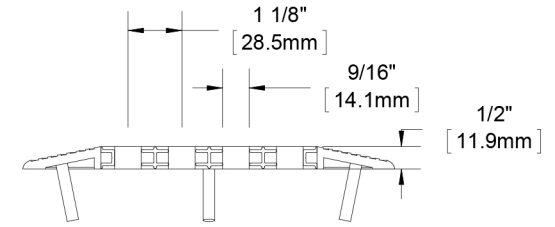

SECTION Y-Y

SINGLE TREAD

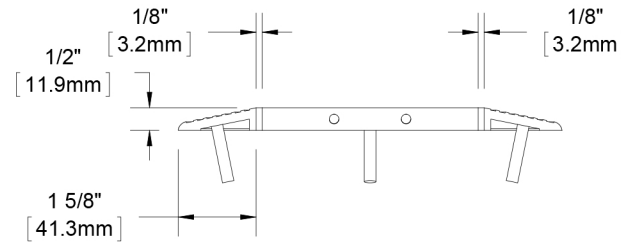
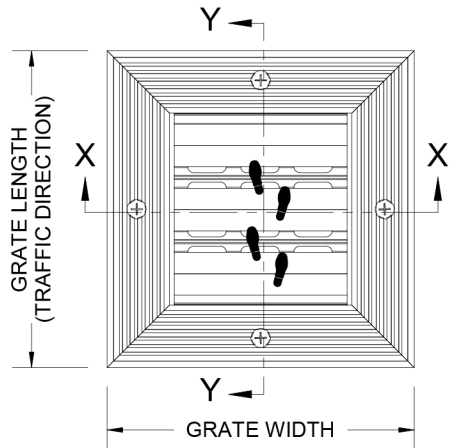

SECTION X-X

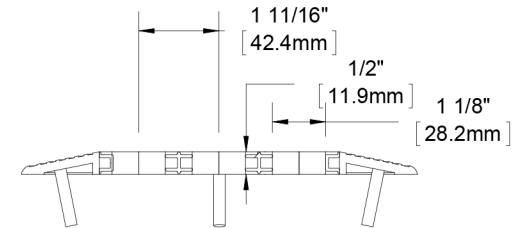

SECTION Y-Y

DOUBLE TREAD

NOTES:

- STANDARD MAXIMUM SECTION SIZE OF GRATE WIDTH NOT TO EXCEED 10'-0"
- FRAME ANCHOR SPACING: 6" FROM CORNERS, 24" MAX
- VERIFY TRAFFIC DIRECTION
- ALL RAIL COMPONENTS ARE MADE OF 6063-T6 ALUMINUM ALLOY, ALL FRAME COMPONENTS ARE MADE OF 6063-T5 ALUMINUM ALLOY
- TREAD RAILS MUST RUN PERPENDICULAR TO TRAFFIC DIRECTION
- GRATE DIMENSION ALLOWS FOR CLEARANCE BETWEEN GRATE SECTIONS AND FRAMES IN THE WIDTH DIMENSION

DESCRIPTION:

enviRONtread II®. 15/32", Perforated Rail, Reversible Recycled Rubber Grate with Surface Mount Aluminum Frame

BGV120-FSAM

SCALE: NTS

F-12

Harbor City Supply Inc. 9515 Deereco Road Suite 1012, Timonium, Md. 21093

Phone 443-279-0632 or 1-800-260-0907

Fax 443-279-0015

rick@harborcitysupply.com