

BGV12C

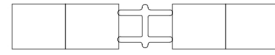

BGV12CC

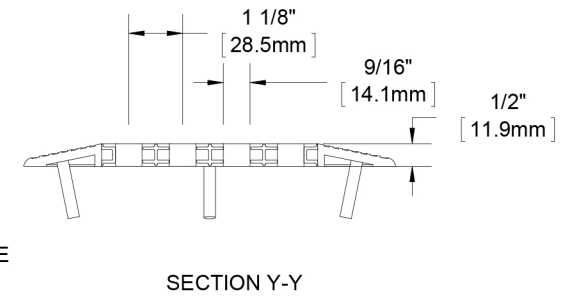
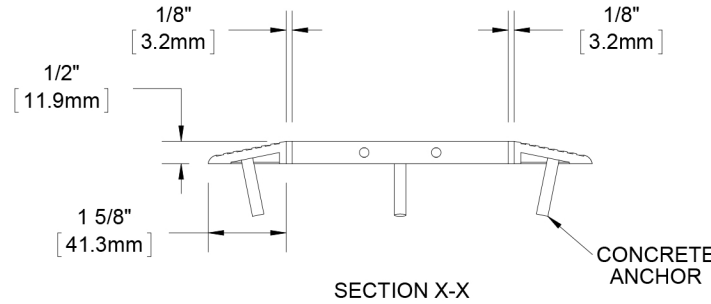
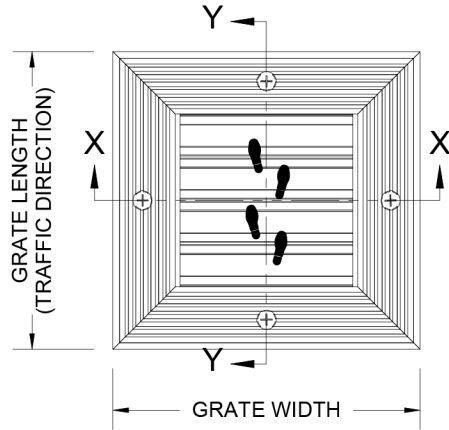

SINGLE TREAD

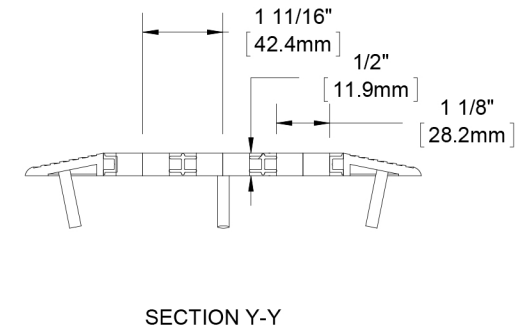
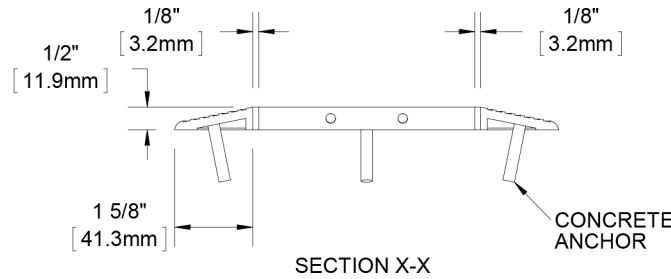
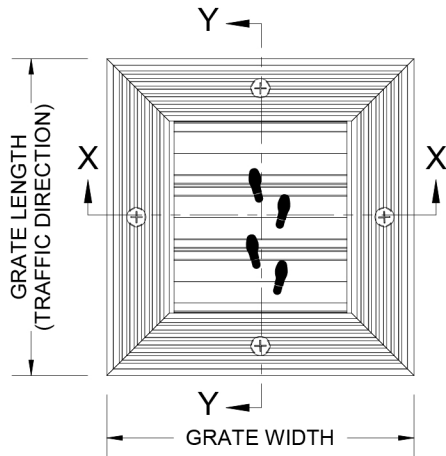

DOUBLE TREAD

NOTES:

- STANDARD MAXIMUM SECTION SIZE OF GRATE WIDTH NOT TO EXCEED 10'-0"
- FRAME ANCHOR SPACING: 6" FROM CORNERS, 24" MAX
- VERIFY TRAFFIC DIRECTION
- ALL RAIL COMPONENTS ARE MADE OF 6063-T6 ALUMINUM ALLOY, ALL FRAME COMPONENTS ARE MADE OF 6063-T5 ALUMINUM ALLOY
- TREAD RAILS MUST RUN PERPENDICULAR TO TRAFFIC DIRECTION
- GRATE DIMENSION ALLOWS FOR CLEARANCE BETWEEN GRATE SECTIONS AND FRAMES IN THE WIDTH DIMENSION
- ADDITIONAL INFORMATION CAN BE FOUND IN THE PRODUCT SPECIFICATION AND IS CONSIDERED PART OF THIS TRANSMITTAL.
- FRAME PART NUMBER: BFV12SAM

DESCRIPTION:

envIRONtread II®, 15/32", Reversible
Recycled Rubber Grate with Surface
Mount Aluminum Frame

BGV12C-FSAM

SCALE: NTS

F-12

Harbor City Supply Inc. 9515 Deereco Road Suite 1012, Timonium, Md. 21093

Phone 443-279-0632 or 1-800-260-0907

Fax 443-279-0015

rick@harborcitysupply.com