

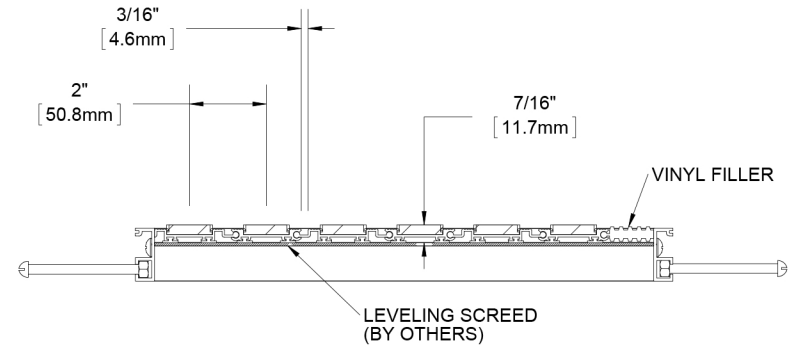

*BMD38P PREMIUM CARPET INSERT
 *BMD38R RUGGED SCRUB INSERT
 *BMD38E ECOTREAD INSERT
 *BMD38U RIBBED RUBBER INSERT
 *BMD38V VINYL INSERT
 BMD38G ABRASIVE VINYL INSERT
 *BMD38B BRUSH INSERT

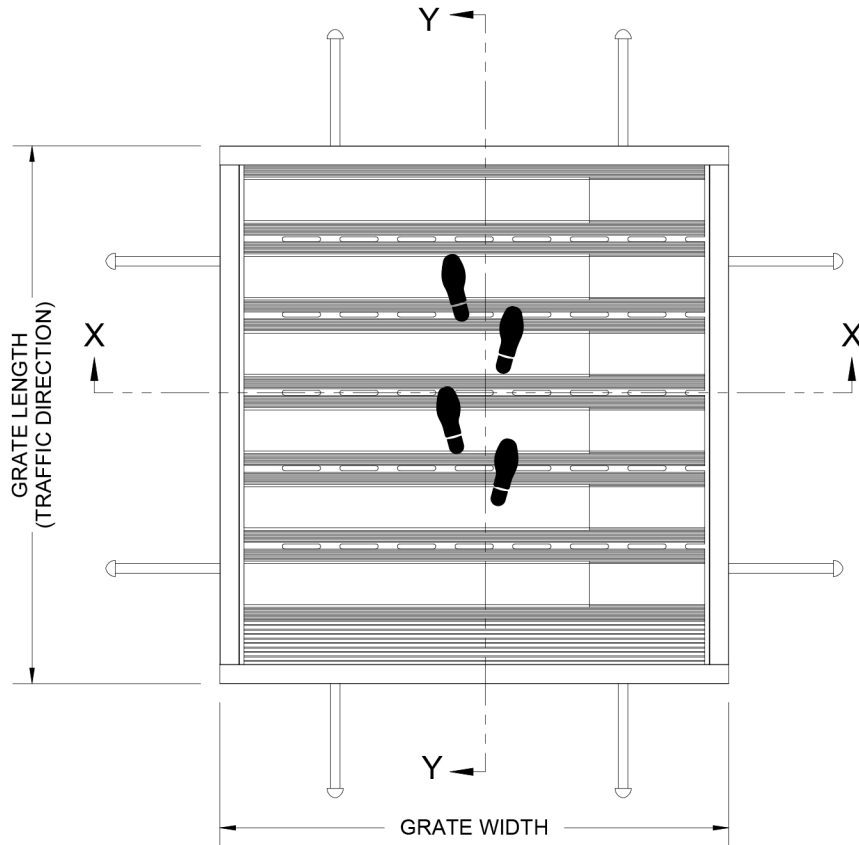

SECTION Y-Y

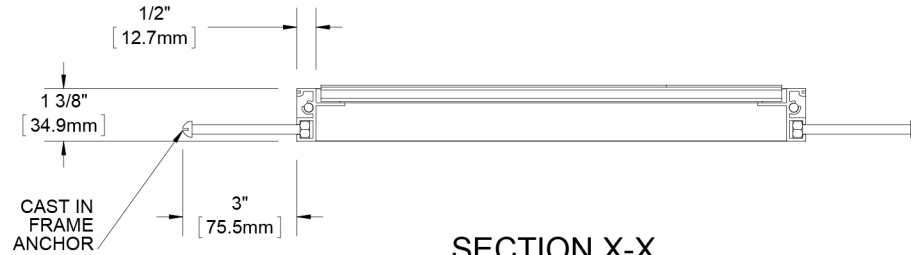

SECTION X-X

NOTES:

- STANDARD MAXIMUM SECTION SIZE OF GRATE/MAT WIDTH NOT TO EXCEED 10'-0" UNLESS OTHERWISE SPECIFIED
- FRAME ANCHOR SPACING: 6" FROM CORNERS, 24" MAX
- VERIFY TRAFFIC DIRECTION AND THAT SECTIONING DOES NOT OCCUR IN A TRAFFIC LANE
- ALL RAIL COMPONENTS ARE MADE OF 6063-T6 ALUMINUM ALLOY, ALL FRAME COMPONENTS ARE MADE OF 6063-T5 ALUMINUM ALLOY (NOT APPLICABLE WITH VINYL SURFACE MOUNT FRAME)
- TREAD RAILS MUST RUN PERPENDICULAR TO TRAFFIC DIRECTION
- TRIM THE FILLER PROVIDED TO ENSURE A TIGHT FIT IN THE TRAFFIC DIRECTION (NOT APPLICABLE WITH VINYL SURFACE MOUNT FRAME)

DESCRIPTION:

MATdesign®, 3/8", Aluminum, Roll-up Mat with Cast In Place, Level Bed, Aluminum Frame

BMD38-FLBC

SCALE: NTS

F-3

* AVAILABLE IN ALTERNATING TREADS

Harbor City Supply Inc. 9515 Deereco Road Suite 1012, Timonium, Md. 21093

Phone 443-279-0632 or 1-800-260-0907

Fax 443-279-0015

rick@harborcitysupply.com