

Similar picture

Grab bar (ADA) 801.36US210

- rail curved at right-angles at the ends with steel fixing roses and centrally positioned third support
- for holding onto and as a support
- with corrosion-protected steel core throughout
- wall mounting with wall-specific fixing material and roses from HEWI
- c to c 42 inch (1067 mm), 2 3/4 inch (70 mm) deep
- rail diameter 1 5/16 inch (33 mm), rose diameter 2 3/4 inch (70 mm)
- suitable for removable hanging seats 801.51US100 and 801.51US110
- maximum loading capacity 330 lbs (150 kg)
- made from high-grade synthetic material in the HEWI colors 99 (pure white), 95 (stone gray), 92 (anthracite gray), 90 (jet black), 86 (sand), 84 (umber) and 33 (ruby red)
- meets the requirements of 2010 ADA standards and ICC/ANSI A117.1-2017
- toilet paper holder upgrade kit 801.50US010 can be retrofitted



Dimensions in mm

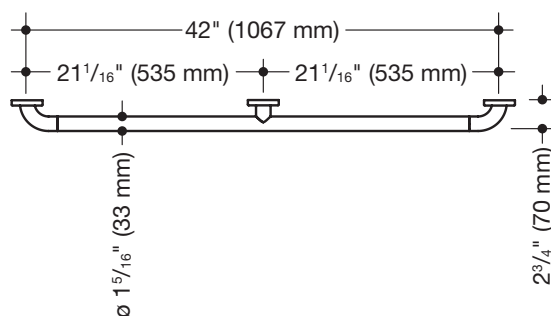

Colours

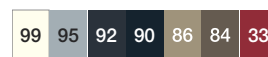

Polyamide

Alternative colours

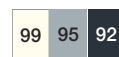

Polyamide, mat

Technical information subject to alteration, 12th August 2021

HEWI Heinrich Wilke GmbH
Postfach 1260
D-34442 Bad Arolsen

Telefon: +49 5691 82-366
Telefax: +49 5691 82-99366
international@hewi.com
www.hewi.com

HEWI (UK) Limited
Holm Oak Barn, Beluncle Halt
Stoke Road
Hoo Kent ME3 9NT

Phone +44 1634 258 200
Fax +44 1634 250 099
info@hewi.co.uk
www.hewi.com