

Date:

Project Name:

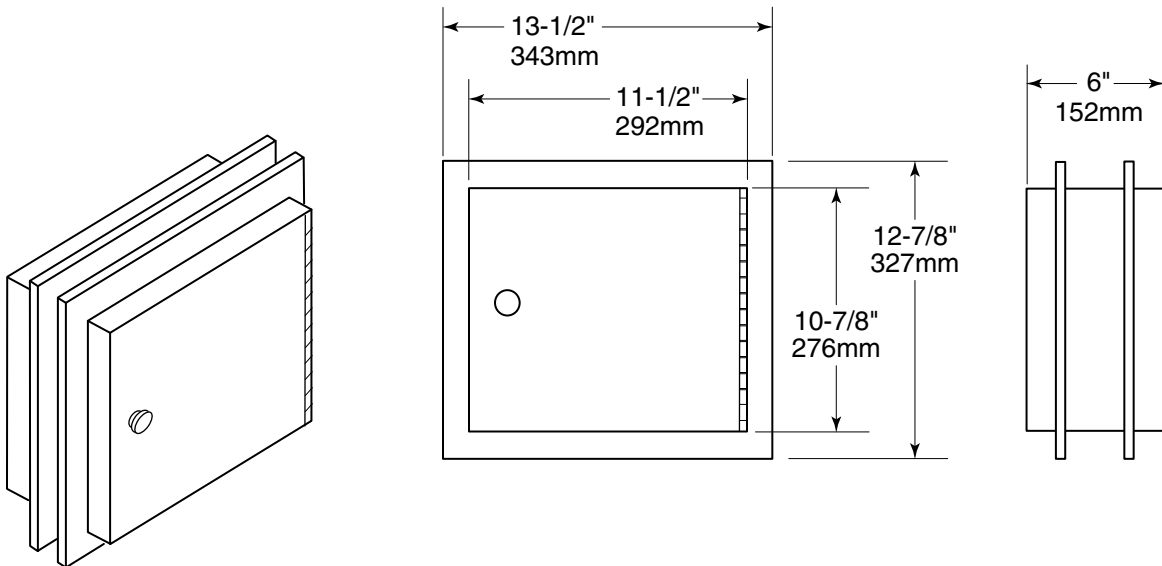

Rough Wall Opening

12" (305mm) wide
11-1/4" (286mm) high
1-3/4" to 5-1/2" (44 to 138mm)
minimum recessed depth

CONSTRUCTION:

Unit fabricated of type 304 HEAVY GAUGE stainless steel. All welded construction with exposed surfaces having a #4 satin-finish. One piece seamless flange provided with 1/4" (6mm) return for rigidity and mounting hole. EXTRA HEAVY 18-gauge (1.2mm) stainless steel doors are self-closing. Doors are mounted on a continuous stainless steel piano-hinge and provided with a pull knob. Door shall be equipped with interlocking mechanism to prevent the door from opening when the other door is open, providing sight barrier for privacy. Removable tray provided.

Specimen Pass-Thru Cabinet shall be Model SPB-1 of Gamco Commercial Restroom Accessories, One Gamco Place, Durant, OK, 74701-1910