



AMERICAN SPECIALTIES, INC.
 441 Saw Mill River Road, Yonkers, NY 10701
 (914) 476.9000 • (914) 476.0688
 www.americanspecialties.com

MODEL №: 8204

ISSUED: 01-87

REVISED: 12 SEP 2019

COMPACT PADDED RECTANGULAR FOLD-UP SHOWER SEAT (Pg 1 of 2)

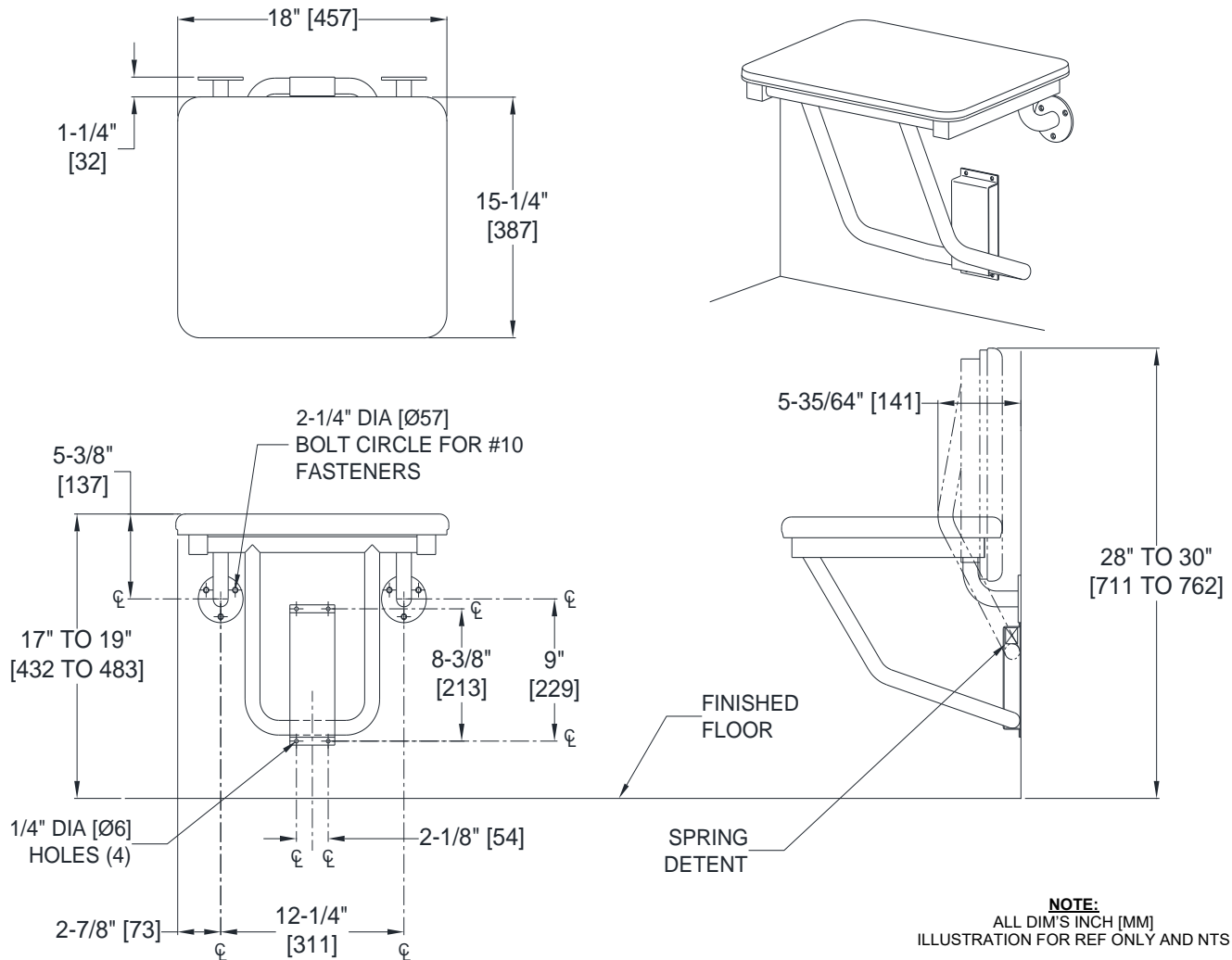

SPECIFICATION

Compact Padded Rectangular Fold-up Shower Seat shall have all metal parts fabricated of 18-8 alloy type 304 stainless steel. Seat frame and support legs shall be 1" dia [Ø25] and 1-1/4" [32] square x 18 gauge [1,2] with 3/16" [4,8] thick mounting flanges and 16 gauge [1,5] guide bracket/arm support. All exposed surfaces shall have satin finish. Structural assembly shall be of welded construction and all exposed edges and corners shall be radiused and/or deburred. Seat shall be sponge cushion covered with off-white Naugahyde® mounted on 1/2" [13] thick marine grade plywood. Support arm shall fold up when in retracted position to provide low profile against wall. No extra fittings shall be required to retain seat in storage position. Guide bracket shall control seat lowering into operating position. Unit shall satisfy 2010 ADA Accessibility Standards when mounted properly.

Compact Padded Rectangular Fold-up Shower Seat shall be Model № 8204 of American Specialties, Inc., 441 Saw Mill River Road, Yonkers, NY 10701-4913

INSTALLATION

This unit is surface mounted. Installer/construction contractor must provide concealed anchor plate or blocking as specified in construction documents or as required by local building codes prior to wall finishing. Fasten unit flanges and guide bracket to concealed anchor or blocking plate with appropriate hardware. See "STRENGTH" section below. Note that concealed mounting plates or anchors and hardware are not supplied with this product and must be specified separately. Ensure that mounting configuration complies with local building codes.



AMERICAN SPECIALTIES, INC.
441 Saw Mill River Road, Yonkers, NY 10701
(914) 476.9000 • (914) 476.0688
www.americanspecialties.com

MODEL No: 8204

ISSUED: 01-87

REVISED: 12 SEP 2019

COMPACT PADDED RECTANGULAR FOLD-UP SHOWER SEAT (Pg 2 of 2)

STRENGTH

ASI Shower Seats are designed to meet and exceed 2010 ADA Accessibility Standards and ICC/ANSI A117.1 so that fabricated product shall be of adequate strength to support a load of 250 lbs (113,4 kg) and unit shall conform to size and edge clearances as diagrammed. Mounting to the wall is a critical part of the system to meet this requirement. To withstand the shear, tension or pullout, and torsion loads generated by the maximum loading, the fastener system must be adequately sized. Unit will carry a load of 500 lbs (226,8 kg) if properly installed. The supporting wall must be adequately reinforced to carry the rated load for the products lifetime.

MATERIALS

Tube: 18 gauge (.048 in. [1,22] thick) type 304 stainless steel, 1" dia. [Ø25] and 1-1/4" [32] square. Unitized all welded construction. Exposed surfaces are satin finish. Edges and corners are radiused and burr free.

Flange: 3/16" [4,8] type 304 stainless steel. Exposed surfaces have satin finish. Edges and corners are radiused and burr free.

Bracket: 16 gauge (.06 in. [1,52] thick) type 304 stainless steel. Exposed surfaces are satin finish. Edges and corners are radiused and burr free.

Seat: Closed cell medium density foam cushion covered with off-white Naugahyde® on a 1/2" [13] thick base of marine grade plywood. Seat cover top edge seam is sewn internally, laid flat and restitched for strength and smooth comfort. Bottom edge seam is tuck-and-roll construction. All seams are sewn using mildew-resistant Nylon® heavyweight thread. Bottom is fully covered and edges are tucked and concealed stainless steel stapled to base. Concealed mounting is from bottom with stainless steel screws into stainless steel inserts. Overall size 18" W X 15-1/4" D [457 X 387]

Spring: Stainless steel type 304, OD 27/32" [Ø216] coils x 2-1/4" [57,2] body length x .085" [Ø2,2] Wire Dia.

OPERATION

Fold-up Shower Seat requires only one hand operation to manually lower to horizontal position for use or raise for departure and arrival. Guide bracket with spring detent prevents seat from dropping and provides positive support in usage position as well as spring locked storage position.