



**AMERICAN SPECIALTIES, INC.**  
 441 Saw Mill River Road, Yonkers, NY 10701  
 (914) 476.9000 • (914) 476.0688  
 www.americanspecialties.com

**MODEL №:** 8203

**ISSUED:** 01-87

**REVISED:** 12 SEP 2019

**COMPACT RECTANGULAR PHENOLIC FOLD-UP SHOWER SEAT (Pg 1 of 2)**

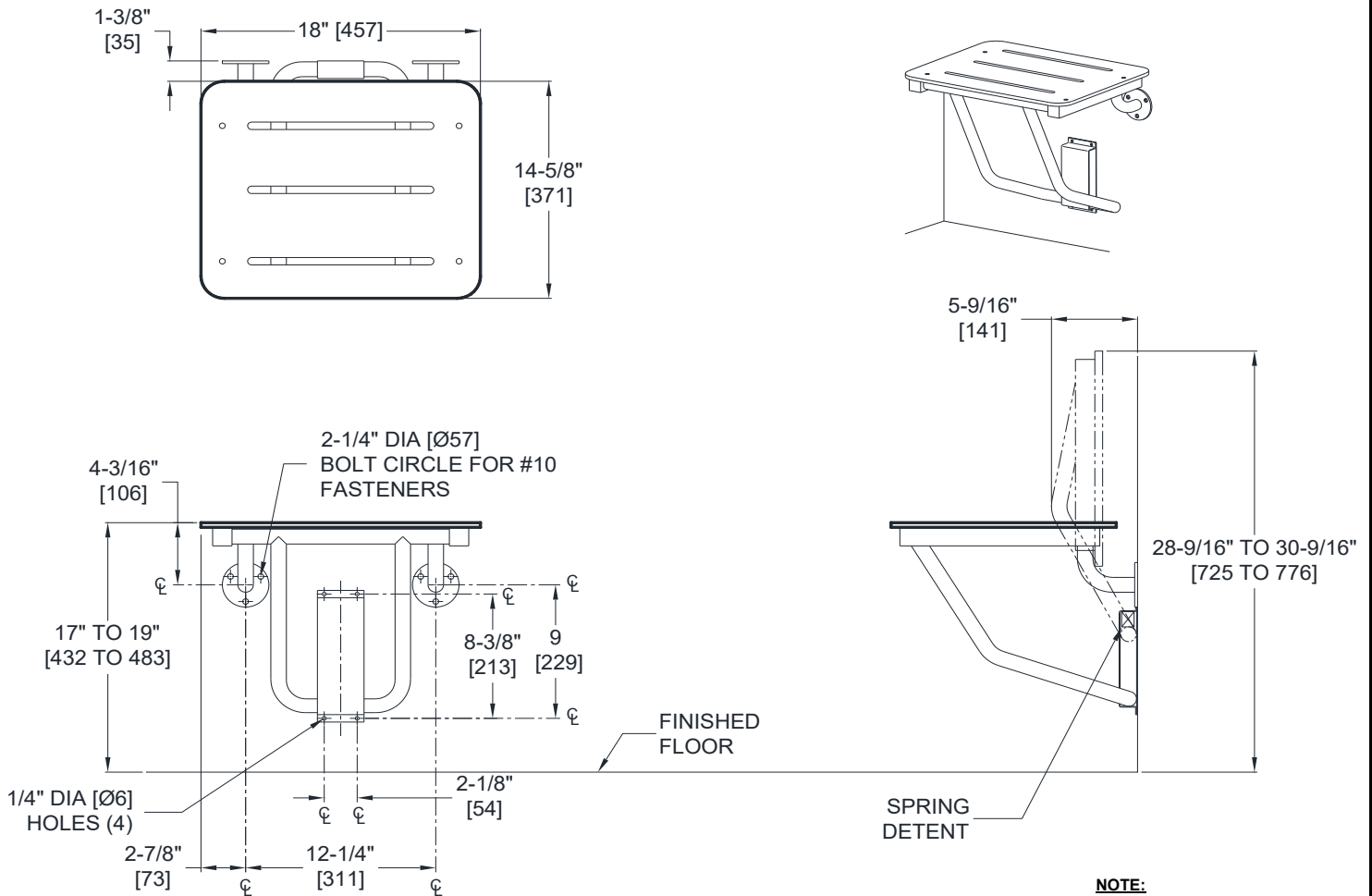

**NOTE:**  
 ALL DIM'S INCH [MM]  
 ILLUSTRATION FOR REF ONLY AND NTS

**SPECIFICATION**

Compact Rectangular Phenolic Fold-up Shower Seat shall have all metal parts fabricated of 18-8 alloy type 304 stainless steel. Seat frame and support legs shall be 1" diameter [Ø25] and 1-1/4" [32] square x 18 gauge [1,2] with 3/16" [4,8] mounting flanges and 16 gauge [1,5] guide bracket/arm support. All exposed surfaces shall have satin finish. Seat shall be 5/16" [8] thick phenolic with white color top and bottom surfaces and shall have black edges. Structural assembly shall be of welded construction and all exposed edges and corners shall be radiused and/or deburred. Support arm shall fold up when in retracted position to provide low profile against wall. No extra fittings shall be required to retain seat in storage position. Guide bracket shall control seat lowering into operating position. Unit shall satisfy 2010 ADA Accessibility Standards when mounted properly.

**Compact Rectangular Phenolic Fold-up Shower Seat shall be Model № 8203 as manufactured by American Specialties, Inc., 441 Saw Mill River Road, Yonkers, NY 10701-4913**

**INSTALLATION**

This unit is surface mounted. Installer/construction contractor must provide concealed anchor plate or blocking as specified in construction documents or as required by local building codes prior to wall finishing. Fasten unit flanges and guide bracket to concealed anchor or blocking plate with appropriate hardware. See "STRENGTH" section below. Note that concealed mounting plates or anchors and hardware are not supplied with this product and must be specified separately. Ensure that mounting configuration complies with local building codes.



**AMERICAN SPECIALTIES, INC.**  
441 Saw Mill River Road, Yonkers, NY 10701  
(914) 476.9000 • (914) 476.0688  
www.americanspecialties.com

**MODEL №:** 8203

**ISSUED:** 01-87

**REVISED:** 12 SEP 2019

## COMPACT RECTANGULAR PHENOLIC FOLD-UP SHOWER SEAT (Pg 2 of 2)

### STRENGTH

ASI Shower Seats are designed to meet and exceed 2010 ADA Accessibility Standards and ANSI A117.1 so that fabricated product shall be of adequate strength to support a load of 250 lbs (113,4 kg) and unit shall conform to size and edge clearances as diagrammed. Mounting to the wall is a critical part of the system to meet this requirement. To withstand the shear, tension or pullout, and torsion loads generated by the maximum loading, the fastener system must be adequately sized. Unit is load rated to support a weight of 500 lbs (226,8 kg) if properly installed. The supporting wall must be adequately reinforced to carry the rated load for the products lifetime.

### MATERIALS

**Tube:** 18 gauge (.048" [1,22] thick) type 304 stainless steel, 1" [Ø25] dia. and 1-1/4" [32] square. Unitized all welded construction. Exposed surfaces are satin finish. Edges and corners are radiused and burr free.

**Flange:** 3/16" [4,8] type 304 stainless steel. Exposed surfaces have satin finish. Edges and corners are radiused and burr free.

**Bracket:** 16 gauge (.06" [1,52] thick) type 304 stainless steel. Exposed surfaces are satin finish. Edges and corners are radiused and burr free.

**Seat:** Solid Phenolic 5/16" x 14-5/8" x 18" [8 x 371 x 457]. Exposed surfaces have semi-gloss laminate white top and bottom surfaces and shall have black edges. Corners are radiused, edges are champhered, and burr free. Seat top shall have three [3] slots 1/4" wide x 12" long [6 x 305] for water drainage and user slip resistance. Mounting hardware is stainless steel dome head carriage bolts with acorn nuts on bottom.

**Spring:** Stainless steel wire type 304 OD 27/32" [Ø21,6] coils x 2-1/4" body length [57,2] x .085" [Ø2,2] wire diameter.

### OPERATION

Fold-up Shower Seat requires only one hand operation to manually lower to horizontal position for use or raise for departure and arrival. Guide bracket with spring detent prevents seat from dropping and provides positive support in usage position as well as spring locked storage position.