



AMERICAN SPECIALTIES, INC.
 441 Saw Mill River Road, Yonkers, NY 10701
 (914) 476.9000 • (914) 476.0688
 www.americanspecialties.com

MODEL №: 94696A

ISSUED: JAN 2006

REVISED: 15 SEP 2021

RECESSED AUTOMATIC ROLL PAPER TOWEL DISPENSER AND WASTE RECEPTACLE

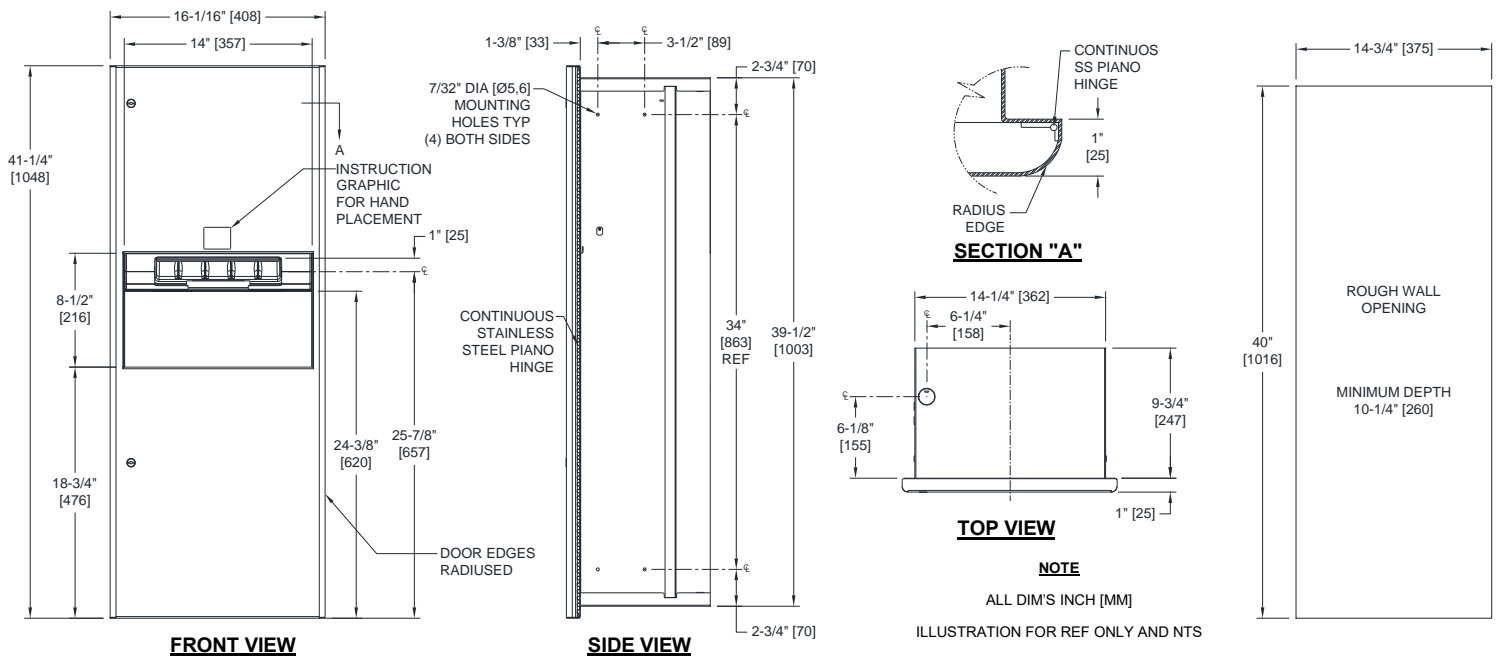

SPECIFICATION

Recessed Automatic Roll Paper Towel Dispenser and Waste Receptacle shall hold and dispense one 8" [203] wide x 8" Dia. [Ø203] standard towel roll up to 800 ft. [244m] long and one 8" [203] wide stub roll up to 4" Dia. [Ø102] and shall have a waste capacity of 10 gallons (38 L). Automatic Touchless Roll Paper Towel Dispenser shall be powered by four (4) D-size batteries (not supplied) and operate automatically to activate towel dispensing when hands are placed in sensor zone from 1/2" [13] below sensor to 4-1/2" [114] below sensor. At each activation unit shall feed out a length of towel selected by owner by setting length, delay and paper saver switches. Unit shall have an internal towel cut-off bar. Full-face door, cabinet and waste receptacle shall be type 304 stainless steel alloy 18-8. All exposed surfaces shall have satin finish and shall be protected during shipment with PVC film easily removable after installation. Cabinet, back and frame shall be 20 gage stainless steel with 1" [25] wide perimeter trim to lay flat against wall. Full-face door shall be 16 gage and shall be free of miters, welding or open seams with 3/4" [19] radiused vertical edges and 1" [25] square horizontal returns to wall and towel dispensing opening shall have a full return and formed sill at top edge for user safety. Door shall be attached to the edge of unit with a concealed full length 3/16" Dia. [Ø4,8] heavy duty stainless steel multi-staked piano hinge and shall be held closed with two (2) flush rimless tumbler locks keyed alike to other ASI washroom equipment. Interior waste receptacle shall have a welded on finger pull for ease of service removal and maintenance safety. Structural assembly of all components shall be of welded construction. Cabinet shall have no exposed fastening devices or spot-welded seams.

Recessed Automatic Roll Paper Towel Dispenser and Waste Receptacle shall be Model № 94696A as manufactured by American Specialties, Inc., 441 Saw Mill River Road, Yonkers, NY 10701-4913

INSTALLATION

Install unit in wall with four (4) № self-threading pan head or flat head screws (by others) through concealed mounting holes provided. Note that top of Rough Wall Opening (RWO) is 5/8" [16] below top of unit. For compliance with ANSI A-117.1, 2015 ABA Standards and 2010 ADA Accessibility Standards install unit so that top edge of towel dispenser opening is 48" [1219] Maximum Above Finished floor (Max AFF) only if clear floor reach access is provided. Be advised that local codes may require mounting so that top of towel dispenser opening is 40" [1016] Max AFF (e.g. California UBC/Title 24). For general utility install unit with top of towel dispenser opening between 49" [1245] and 56" [1422] AFF.

RWO required is 14-3/4" [375] W x 40" [1016] H x 10-1/4" [260] D Min

OPERATION

Towels are dispensed one length at a time automatically when hands are placed in sensor zone until supply is depleted. Owner predetermines length of towel dispensed by making selections on three (3) three (3)-position switches for length, delay, and economy. Unit may be reloaded with a full roll to automatically start when finished with an existing partial roll and will continue to feed properly when reloaded with a full roll and partial roll is transferred to stub roll position. Refill dispenser by unlocking door and replacing towel roll for an empty or partially empty unit. Locking door prevents unauthorized access and roll removal. Dispenser supply is replenished, batteries are replaced and waste receptacle is emptied manually on cycles determined by maintenance needs.