

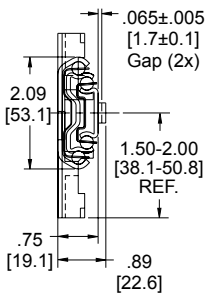

**MODEL 3641 Interlock Slide**  
**MODEL 3642 Companion Slide**

Rod-Based Interlock System  
 180 lb.\*\* [82 kg.] Capacity

**APPLICATIONS:** For lateral files and heavy-duty multi-drawer cabinets where an interlock/anti-tilt system is required. For drawer heights greater than 3.5 inches. **This product is covered by U.S. (5,757,109, 6,296,332) and various foreign patents issued and/or pending.**

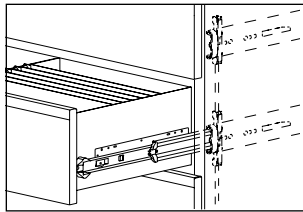

**MODEL 3641**

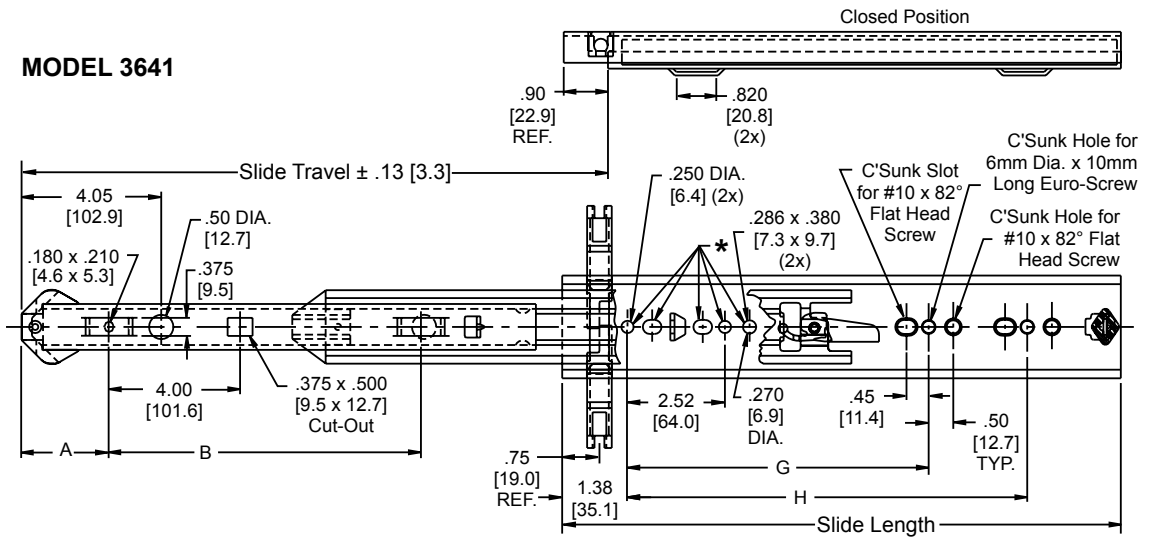

**MODEL 3642**

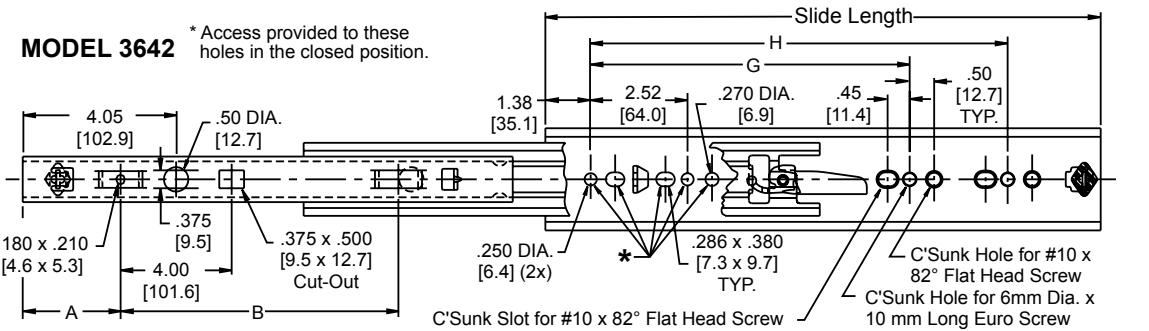

Inches [mm]

<b>Finish</b>	Bright electro-zinc (C) or black zinc (CB) plating available
<b>Lengths</b>	Even lengths 14"–28", plus 17" [353 mm–709 mm, plus 429 mm]
<b>Travel</b>	See Chart
<b>Height</b>	2.09" [53.1 mm] (slide only); 3.50" ± .010 [88.9 mm ± 0.25] minimum spacing between slide center lines
<b>Load</b>	180 lbs. [82 kgs.] per pair **
<b>Side Space</b>	.89" (+ .030 / - .000) [22.6 mm (+ .76 / -0.00)]
<b>Mounting</b>	Cabinet: Traditional (#10 flat head screws) or 32 mm system (Euro) screws Drawer: Adapter bracket (#8 screws)
<b>Hardware</b>	#10 x 82° flat head or 6 mm DIA. x 10 mm long Euro screw
<b>Also</b>	Disconnect using drawer adapter bracket. Sequencing latch, silenced open and close, detent closed

Part Number	Slide Length	Slide Travel	Pocket A	Pocket B	Hole G	Hole H
3641-14	13.90	14.00	1.80	8.50	8.82	-
3642-14	[353]	[356]	[45.7]	[215.9]	[224.0]	
3641-16	15.90	17.00	1.80	10.50	8.82	12.60
3642-16	[404]	[432]	[45.7]	[266.7]	[224.0]	[320.0]
3641-17	16.90	18.00	1.80	10.50	8.82	12.60
3642-17	[429]	[457]	[45.7]	[266.7]	[224.0]	[320.0]
3641-18	17.90	19.00	1.80	10.50	8.82	13.86
3642-18	[455]	[483]	[45.7]	[266.7]	[224.0]	[352.0]
3641-20	19.90	21.00	2.80	10.50	8.82	16.38
3642-20	[505]	[533]	[71.1]	[266.7]	[224.0]	[416.0]
3641-22	21.90	23.00	2.80	12.50	12.60	16.38
3642-22	[556]	[584]	[71.1]	[317.5]	[320.0]	[416.0]
3641-24	23.90	25.00	2.80	12.50	12.60	18.90
3642-24	[607]	[635]	[71.1]	[317.5]	[320.0]	[480.0]
3641-26	25.90	27.00	2.80	15.50	12.60	21.42
3642-26	[658]	[686]	[71.1]	[393.7]	[320.0]	[544.0]
3641-28	27.90	29.00	2.80	15.50	12.60	23.94
3642-28	[709]	[737]	[71.1]	[393.7]	[320.0]	[608.0]

\*\* Load rating based on an 18" slide on a 42" wide drawer cycled 75,000 times.

**Cabinet Mounting Instructions**

**Traditional Mounting**

Install cabinet members using #10 x 82° flat head screws. Refer to Figure 1 for cabinet hole locations. Be sure slides are parallel. Front of slide is set flush with cabinet front for overlay drawer fronts. Install screws in second hole (horizontal slot) and rear most horizontal slot.

**NOTE:** Due to the heavy load capability and limitations of screw retention in wood products, Accuride recommends the use of two #10 screws, 3/4" long, at the front of the cabinet member and at least one at the rear.

**Increase by 1/2" (12.7 mm) when using Timberline #AC610 actuator—plus—thickness of drawer front on inset applications.**

-OR-

**32 mm System**

Install cabinet members using 6 mm x 10 mm Euro screws. Refer to Figure 2 for cabinet hole locations. Be sure slides are parallel.

**CAUTION: USE ONLY FLAT HEAD SCREWS FOR MOUNTING CABINET MEMBER!**

**Connecting Rod Recommendations**

Connecting rod length is determined by the center line measurement between adjacent slide cabinet members. See L in Figure 3. From that dimension subtract 2". That becomes the rod length. Rod length should be held to ± .020. Steel or aluminum is the recommended rod material. Rod diameter is 1/4" (.250"). See Figure 4.

**Connecting Rods for Bulk and Distributor Orders**

For bulk orders, customers can supply their own connecting rods or purchase aluminum connecting rods directly from Accuride. See ordering instructions on back page.

For Distributor X-Pack orders, Accuride supplies two 12" aluminum connecting rods. The rods can be cut to length as required. Maintaining ± .020 tolerance is critical to achieve optimum performance.

**Installation of Connecting Rods**

Insert the rod into the upper follower rod pocket of the lower slide. Rotate the rod toward the lower follower rod pocket of the upper slide. Once located, snap the rod into position. See Figure 3. Repeat for all slides mounted into the cabinet.

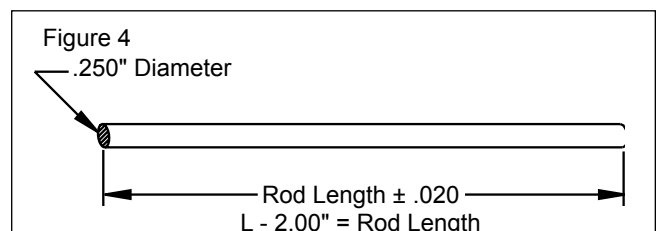
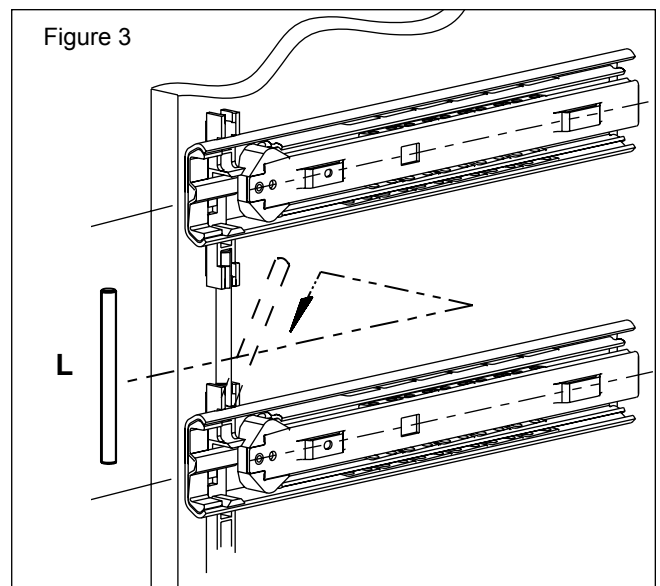
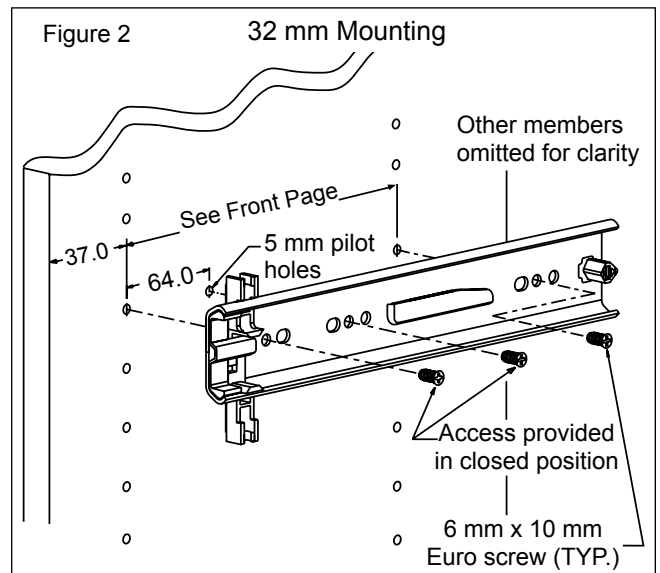
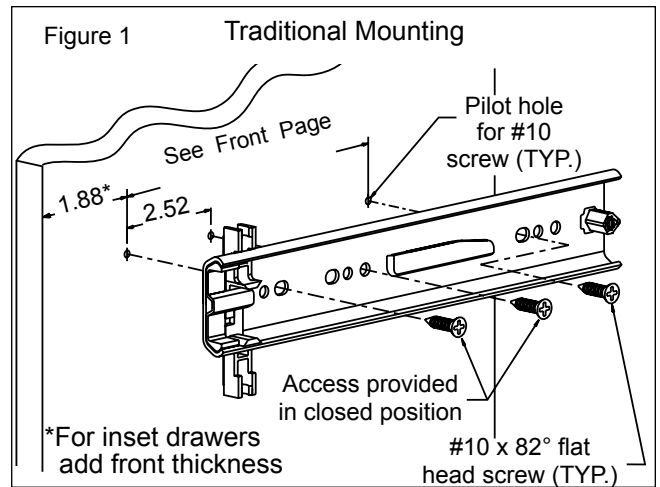

**Drawer Mounting Instructions**

**Drawer Sizes**

The bracket system will accommodate drawer heights 3.50" (89 mm) or greater and widths to 42".

**Wood Drawer**

Refer to Figure 5 for front and rear mounting bracket hole locations and install screws through vertical slots. Drawer mounting holes should be placed on a line 1.38" above slide center line, with the first hole located .31" plus Pocket "A" dimension (see chart on front page) behind drawer front. Extend the slides fully forward. Mount drawer slide by lowering the rear bracket tabs through the rear slide pocket (see Figure 6). Lower drawer until front bracket tabs snap into front pockets.

◆ **Becomes A + .31" [7.9 mm] when using Timberline #AC610 actuator.**

Close drawer fully to locate horizontal slide position in cabinet. Open drawer to adjust and install remaining screws. Secure brackets after adjusting the drawer vertically and horizontally.

**NOTE:** To remove, lift drawer up and outward. Drawer can be permanently fixed to the cabinet using a screw through the front pocket hole, or bending the locking tab.

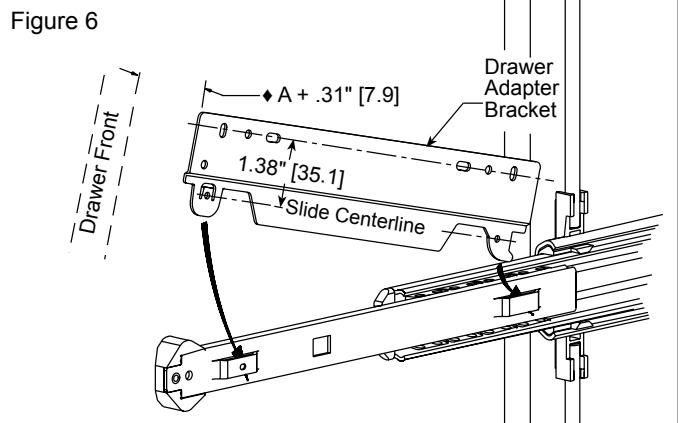
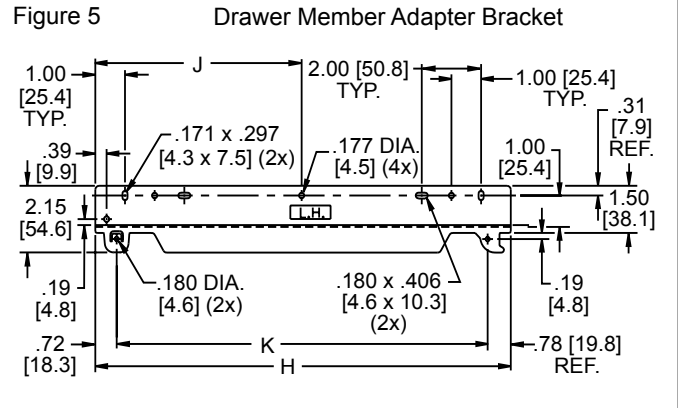

Drawer Adapter Brackets				
Slide Length	Part Number	H	J	K
14"	5430-1216-CL 5430-1216-CR	10.00"	-	8.50"
16"-20"	5430-1720-CL 5430-1720-CR	12.00"	-	10.50"
22"-24"	5430-2124-CL 5430-2124-CR	14.00"	7.00"	12.50"
26"-28"	5430-2528-CL 5430-2528-CR	17.00"	8.50"	15.50"

**Metal Drawer**

**Drawer Cut-Out Recommendations**

Cut-out recommendations are based on 16 gauge material thickness. See Figure 7. For B dimension, see table on front. If a thinner material is used, adjustments to the cut-outs must be made to ensure a proper fit. Refer to the table below for the required modifications if 16-22 gauge material is used.

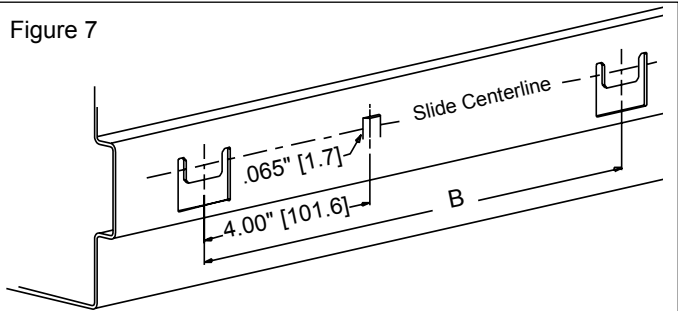

MATERIAL GAUGE	MATERIAL THICKNESS	D	E
16	.060 [1.52]	.855 [21.7]	.815 [20.7]
18	.048 [1.22]	.865 [22.0]	.825 [21.0]
20	.036 [.91]	.885 [22.5]	.845 [21.4]
22	.030 [.76]	.905 [23.0]	.865 [22.0]

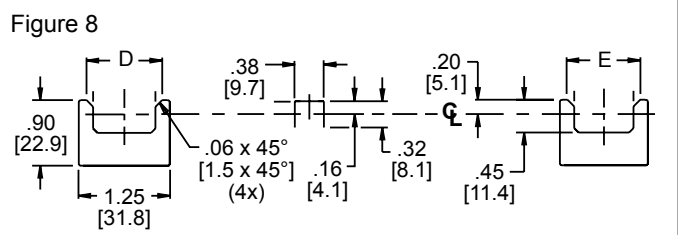

**Mounting Slide to Drawer**

Using recommended placement of drawer bayonets (see Figure 8), extend both right and left hand slide drawer members. See Figure 9.

Position rear drawer tabs into both rear slide pockets. Guide front tabs into front pockets and push firmly into place making sure drawer lug snaps into cut-out on slide drawer member. See Figure 9.

For optimum slide performance, it is recommended that the slide centerline be located at the center line of the drawer side, or slightly toward the plane of the drawer pull.

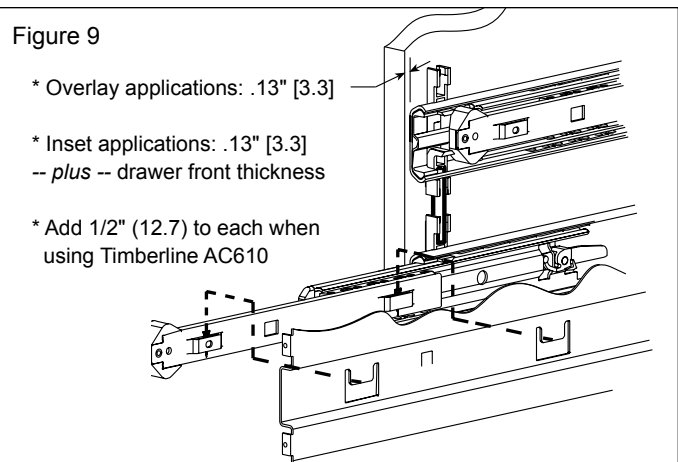

**Side Space**

The basic slide assembly functions best in the following operating space:

- Metal applications: .75" + .030 / - .000 [3/4" + 1/32" / - 0]
- Wood applications: .89" + .030 / - .000 [7/8" + 1/32" / - 0]

**Interlock Strength**

The interlock system is designed to resist 200 pound pull on a blocked drawer (force applied to unopened drawer with one drawer already open). Rods of sufficient stiffness must be used to ensure this capability.

**Self-Closing**

It is common practice on file cabinets to mount the slides with a slight backslope to compensate for cabinet tilting. Limit this angle to 1° for best interlock rod action.

**Spring Load**

Some gang lock interface devices may apply a download on the rod stack. Also, some systems may use a spring-load on the rod stack to achieve a self-closing action for the last 1/2" of closure travel. Optimum cycle life requires this spring load be limited to 5 lbs.

**Cabinet Security Locks**

The interlock system can be used to lock all drawers in the cabinet. An interface device can be applied above the rod stack to simulate the action of an open drawer on existing cabinet designs. A simple cam mechanism can be designed to block the rod stack, driven by the current key lock. A device directly actuated by a lock cylinder cam is available from Accuride (order kit #4180-0345-XE), or directly from Timberline\* (#AC610). Similarly, an actuator driven by a flexible shaft from a center mounted key lock is also available from Timberline by ordering part number #AC600.

**Gang Locking System**

For optional gang locking system, order kit P/N 4180-0345-XE.

- For lock on left **or** right hand side, order 1 kit per unit.
- For lock on **both** sides, order 2 kits per unit.

Kit 4180-0345-XE contains:

- 1 Each 2999-9436-YE (Timberline #AC610)
- 1 Each Installation Sheet

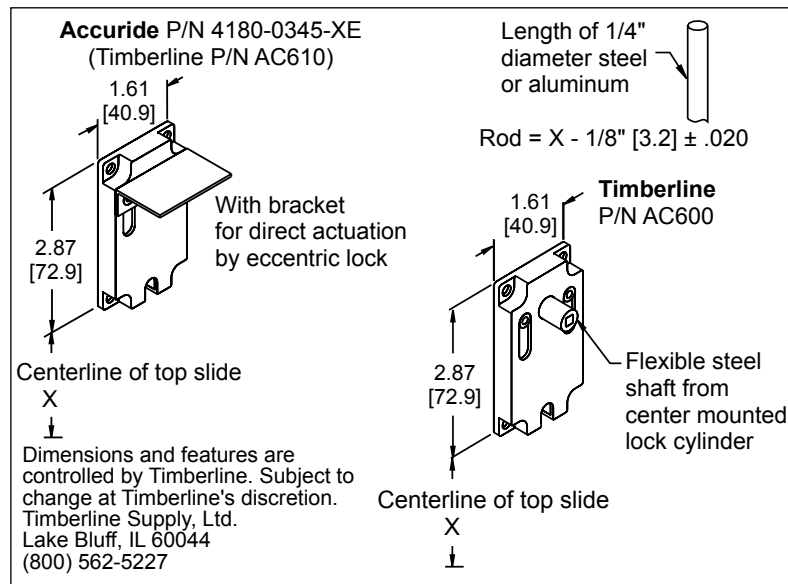

**Specifications**

- Slide members and ball retainers: Cold rolled steel
- Ball bearings: Acetal polymer and carburized steel
- RoHs Compliant

**Note:** Specifications, materials, prices, terms, and delivery are subject to change without notice.

For the most current technical information visit [www accuride.com](http://www accuride.com)

**Interlock and Companion Slides**

Slides are unhandled and ordered as each. Complete your slide order for Accuride model 3641 interlock slide and model 3642 non-locking companion slide by specifying as follows:

	100 Each	C 3641	-16
	100 Each	C 3642	-16
Total Slides Required	_____		
Slide Finish*	_____		
Model 3641 Interlock Slide	_____		
Model 3642 Non-Locking Companion Slide	_____		
Slide Length	_____		

\* "C" for bright zinc, "CB" for black zinc

**Adapter Brackets**

The adapter brackets are handed. Order one left hand (CL) and one right hand (CR) bracket per pair of slides. For part numbers, refer to the chart on page 3. Complete your order for the adapter brackets by specifying as follows:

	100 each	5430-1720	-B L
	100 Each	5430-1720	-C R
Total Brackets Required	_____		
Bracket Part Number	_____		
Bracket Finish*	_____		
Bracket Hand**	_____		

\* "C" for bright electro-zinc, "B" for black zinc  
\*\* "L" for left hand, "R" for right hand

**Connecting Rods**

Aluminium connecting rods are available in bulk and ordered separately. When using the gang locking system, order 1 rod for each drawer (5 drawers = 5 rods). For interlock function only, order 1 rod for each drawer minus 1 (5 drawers minus 1 = 4 rods). Complete your rod order by specifying as follows:

	400 Each	2999-9435	-YE
Total Rods Required	_____		
Rod Part Number	_____		

**Packaging Instructions**

- Bulk Pack:** Model 3641 Lengths 14"-22" 10 ea/box  
Lengths 24"-28" 5 ea/box
- Model 3642 All Lengths 10 ea/box

Adapter brackets and connecting rods ordered separately.

**(X) Pack:** All lengths 2 pr/box

Each box contains:

- 2 Each Interlock Slides (C3641-XX)
- 2 Each Non-Locking Companion Slides (C3642-XX)
- 2 Pair Adapter Brackets (5430-XXXX-CL/CR)
- 2 Each 12" Connecting Rods (2999-9435-YE)
- 1 Each Mounting Screws
- 1 Each Installation Sheet



ACCURIDE INTERNATIONAL INC.

12311 Shoemaker Avenue  
Santa Fe Springs, CA 90670

TEL (562) 903-0200  
FAX (562) 903-0208

[www accuride.com](http://www accuride.com)

Manufacturing, Engineering, and Sales

United States • Germany • Japan • Mexico • United Kingdom • China

Copyright © 2007 Accuride International Inc. 3700-9398(1065)-MK054-R8-0213