

NOTE: FINISH: ONE COAT BAKED ON ENAMEL POWDER COATED FINISH

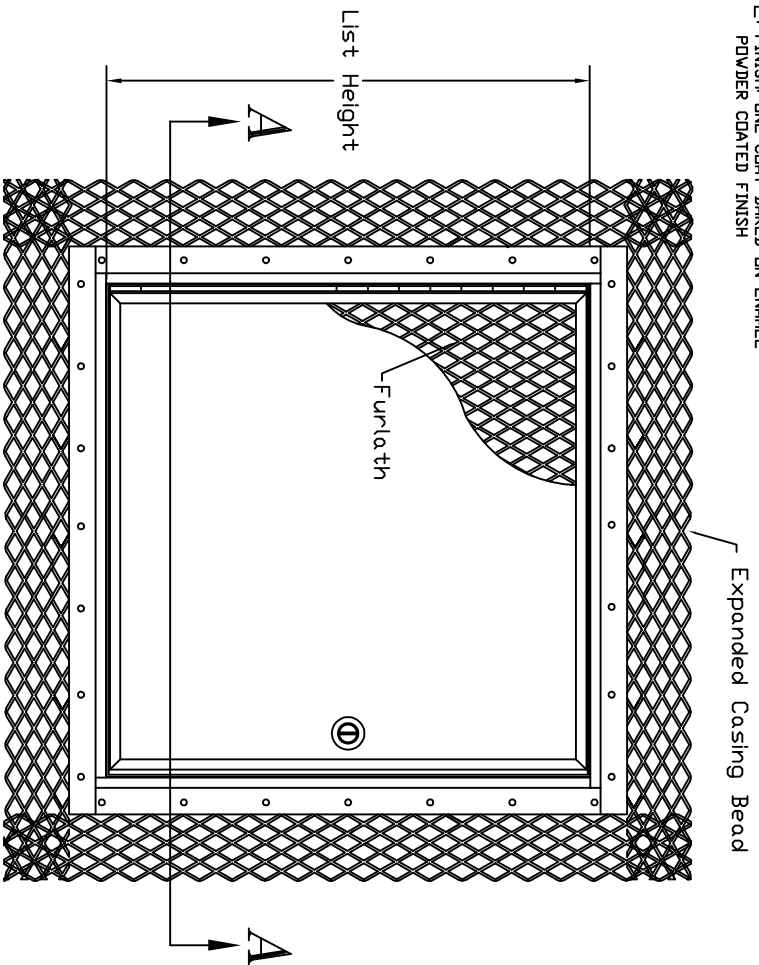

STANDARD SIZES and PRODUCT NUMBERS				
DOOR SIZE	WALL OPENING	PRODUCT NUMBER	No. OF CAMS	Shipping Weight lbs. each
12 x 12	12-1/4 x 12-1/4	3206-014-9	1	9
12 x 24	12-1/4 x 24-1/4	3206-019-9	2	15
18 x 18	18-1/4 x 18-1/4	3206-024-9	2	15
24 x 24	24-1/4 x 24-1/4	3206-030-9	2	24
24 x 36	24-1/4 x 36-1/4	3206-034-9	3	32
36 x 36	36-1/4 x 36-1/4	3206-046-9	5	41

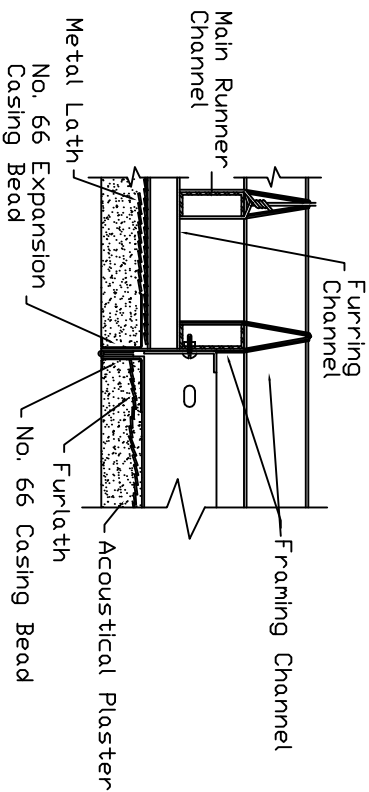

INSTALLATION DETAIL

AP RECESSED PANEL ACCESS DOOR

MATERIAL SCHEDULE

QUANTITY	SIZE	COVER	FRAME

MTCOR

COMMERCIAL PRODUCTS GROUP
484 Thomas Drive
Bensenville, IL 60106
800 624-8642 (fax) 630-766-5259

STANDARD FLUSH DOOR for PLASTER WALLS or CEILINGS

DEALER	
PROJECT	
LOCATION	
ARCH.	
CNT'D	
DATE	DRAWN DCA
REV	JOB NO.
NR13.MILCOR.VAP	SHEET

SECTION VIEW A-A

